

OWNER'S MANUAL

CRANE MACHINE LCM Version

TOY CHEST PIRATE CHEST

TICKET TIME HOT DIAMOND

CANDY CRANE

CANDY CRANE HOUSE

SWEETHEART CANDY CRANE

PRIZE TIME DELUXE

MY LITTLE DUCKS



SMART INDUSTRIES
www.smartind.com

MANUAL VERSION : FI3E-R3-04
ISSUE DATE : 2017.01.03

CONTENTS

Section 1: Safety Notice

Section 2: Component

Section 3: About The Machine

Section 4: Game Introduction

Section 5: Wiring Diagram

Section 6: Troubleshooting

Section 7: Enclosure

Section 1:

Safety Notice

1 SAFETY NOTICE

- a. Please read carefully with enclosure of “Warranty”.
- b. Please read carefully with enclosure of “Maintenance”.
- c. Please check and maintain the machine regularly, DO NOT use any synthetic detergents to clean the machine.
- d. Places where the ground is sloping, uneven or there is strong vibration.
- e. Avoid direct sunlight machine placed in place in case the internal parts damaged.
- f. Avoid machine in high dust, high humidity, high temperature environment, so as to avoid damage to machine parts.
- g. Machine does not have waterproof, limited to indoor use, do not place water & beverages in the machine.
- h. DO NOT climbing or stand above the machine in any time, to avoid a threat to personal safety.
- i. Any casualties which caused by inappropriate behavior and dangerous acts, the Company shall not be responsible.
- j. This appliance is not for children and persons with reduced physical, sensory or mental capabilities or lack of experience and knowledge.
- k. After using this appliance should be cleaned to avoid the accumulation of grease and other residues.
- l. Children should be supervised to ensure that they do not play with the appliance.
- m. If the supply cord is damaged, it must be replaced by the manufacturer, its service agent or similarly qualified persons in order to avoid a hazard.

2 TRANSPORTATION AND MOVING

- a. Before moving the machine, make sure to unplug it from the mains.
- b. Turn off the power as notice before unplug from the mains, inappropriate handling will cause damage to the machine.

3 POWER NOTICE

- a. Before power connecting, verified the voltage is correct. 110V, 220V or 240V
- b. DO NOT touch the plug with damp hands to avoid electric shock.
- c. When installing the device, should ensure a smooth footing.

4 ORDER IN POWER ON

Plug in and turn on the power.



5 ORDER IN POWER OFF

Turn off the power and unplug

 Wait for 10 seconds to reboot

Section 2:
Component

List of Components

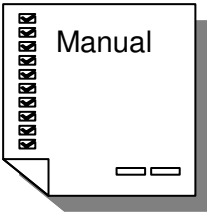
ITEM	DESCRIPTION	PICTURE
a. KEY	QT'Y : 5 REMARK : 2735 x 2 、 3123 x 2	
b. Power line	QT'Y : 1 REMARK : Plug form according area.	
c. Manual	QT'Y : 1 pc REMARK :	

Section 3:

About The Machine

About The Machine: Specifications

a. Voltage & Frequency	Voltage : 100V 、 110V 、 220V 、 240V (Refer to Specification Label) Frequency : 50/60HZ
b. User	1 person
c. Environment	Weather Protected Environment
d. Temperature	0°C~40°C
e. Humidity	10%~70%
f. Power Consumption	Maximum : 660W

Section 4:

Game Introduction

Game Introduction

1 How To Play

a. Game Instruction :

- (1) Insert coin(s)
- (2) Control the claw moving by joystick
- (3) Press CATCH button to catch
- (4) The claw moves to prize hole to release catching of prize

When the machine alarms error code, it will reboot automatically after alarming for 3 minutes. If the machine alarms again within 1 hour after rebooting, it will not reboot again. And it needs troubleshooting. But if the machine alarms again after 1 hour, the machine will reboot as it supposes to be after 3 minutes.

As the machine rebooting for error alarming has been disabled (the machine alarms again after 1 hour), it can be enabled by pressing SETTING button to enter setting page when turning on the machine.

2 System Setting

➤ Electronic Counter

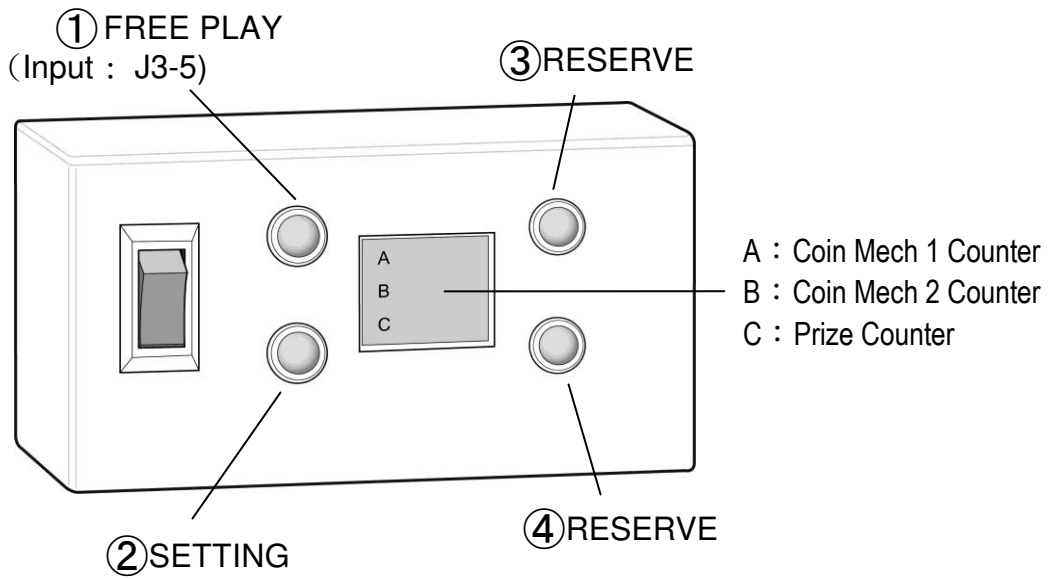

➤ Maintenance Tray

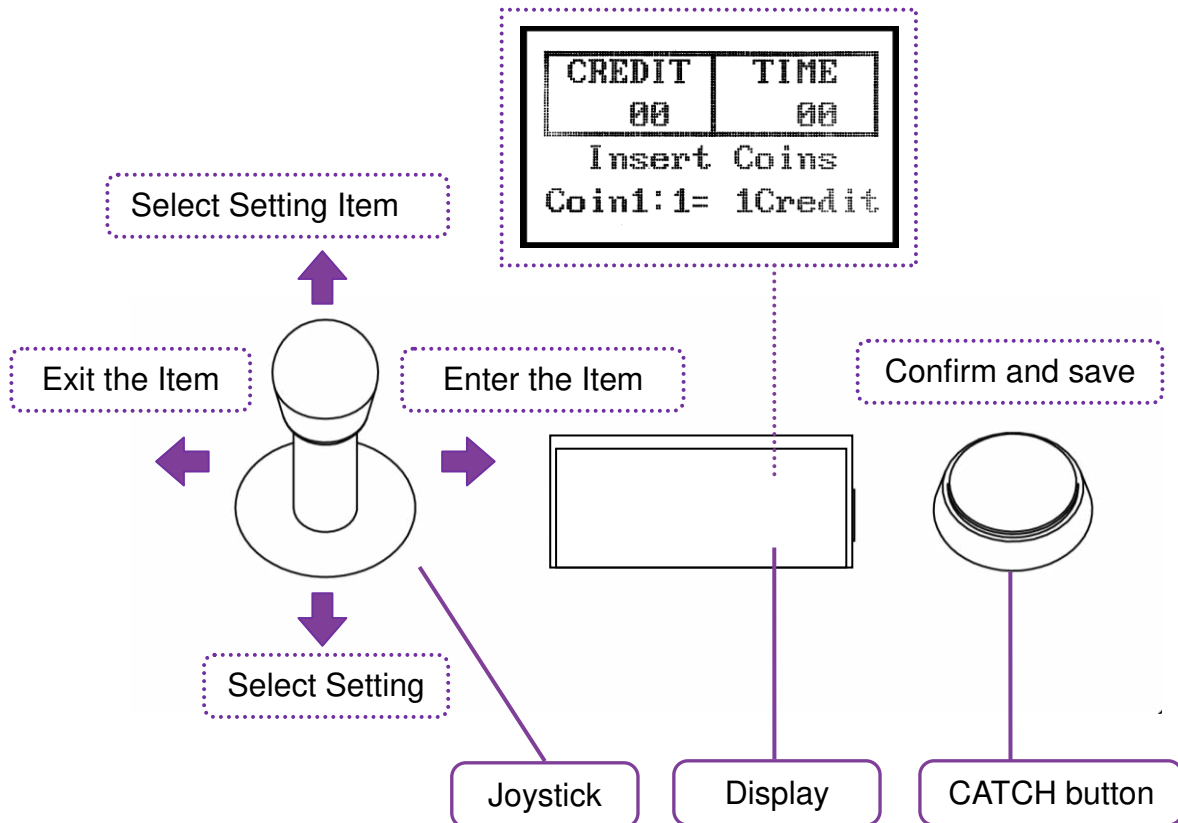

※ The arrangement above will be varied according to different machine version.

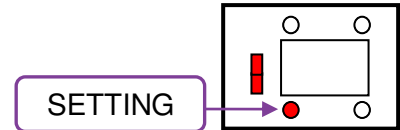

1. To Enter Setting Menu :

※ The range of values will be varied according to different machine specification.
Please refer to actual values on display.

(1) When the machine is in stand-by mode, enter SETTING button to enter setting menu. Or keep pressing SETTING button and turn on the machine to enter setting menu.

(2) 6 main setting items in setting menu :

>>A : Setting
>>B : Clamp Power (Claw Power)
>>C : Accounts
>>D : Play Mode
>>E : Motor Speed
>>F : Test
>>G : Default Value

Joystick: UP or DOWN - select items. RIGHT – enter the item. LEFT - Exit

2. >A : Setting :

>>A1 : Coin->Play
>>A2 : Game time
>>A3 : TSS (Trade Show Settings)
>>A4 : Attract Mu.(Music)
>>A5 : Clamp Catch
>>A6 : Coin Save
>>A7: Play T- Win (Play Till Win)
>>A8: Volume Adj
>>A9 : Clamp Start
>>A10 : Coin Disable/Enable
>>A11 : Clamp End-P (Position)

A1 : Coin->Play :

AA1 : Coin1 Set
AA2: Bill Accept. (Acceptor)
AA3: Credit > Play
AA4: Bonus
AA5 : Coin Display

Joystick : UP or DOWN - select items. RIGHT – enter the item. LEFT - Exit

>AA1 Coin1 Set :

AA1 : Coin1 Set
↑ : + ↓ : - ☀→Exit
1 C = 1 (1~10) Credits

Joystick [Up] / [Down] → Adjust value
[CATCH] ☀ → Save & Exit

> AA 2: Bill Accept. :

AA 2: Bill Accept.
↑ :+ ↓ :- ☀→Exit
1 P = 1 (1~10) Credits

Joystick [Up] / [Down] → Adjust value
[CATCH] ☀ → Save & Exit

AA 3: Credit > Play:

AA 3: Credit > Play
↑ : + ↓ : - ☀→Exit
1 (1~30) Credits =1 Play

Joystick [Up] / [Down] → Adjust value
[CATCH] ☀ → Save & Exit

> AA 4 Bonus :

AA 4: Bonus
↑ : + ↓ : - ☀ → Exit
1 (0~10) Plays +1 Play

COIN1 :

Joystick [Up] / [Down] → Adjust value
[CATCH] ☀ → Save & Exit

> AA 5 Coin Display :

AA 5 : Coin Display
↑ ↓ : Change ☀ ->Exit
>> CREDIT / PLAY

Joystick [Up]/ [Down] → Change setting
Display for : CREDIT OR PLAY.
[CATCH] ☀ → Save & Exit

A2 Game time : (example:30 seconds) ◦

A2 Game time		
↑ :+	↓ :-	☀→Exit
=	30	sec

Joystick [Up] / [Down] → Adjust value
Range : 5~60 seconds
[CATCH] ☀ → Save & Exit

A3 : TSS : (Trade Show Settings)

The explanation below is for a setting of 100.

A3 : TSS		
↑ :+	↓ :-	→Next
=	100	
>>MODE: Random / Set		

Joystick [Up] / [Down] → Adjust value
Joystick [Right] / [Left] → Select
Range : 0~1000
MODE : Random / Set.
[CATCH] ☀ → Save & Exit

A4 : Attract Music :

(The explanation below is for demo music sounding per 5 minutes.)

A4 : Attract Mu.(Music)		
↑ :+	↓ :-	☀→Exit
->ON=	5	minutes

Joystick [Up] / [Down] → Adjust value
Range : 1~30 minutes or disable ◦
[CATCH] ☀ → Save & Exit

A5 : Clamp Catch Position:

A5 : Clamp Catch
↑ ↓ : Change ☀ ->Exit
= At Air / At Bottom

Joystick [Up] / [Down] → Change setting

AT AIR – Available to catch in before claw reaches the bottom

AT BOTTOM—Only catch when claw reach the bottom

[CATCH] ☀ → Save & Exit

A6 : Coin Save :

A6 : Coin Save
↑ ↓ : Change ☀ ->Exit
=Save / Clear

Joystick [Up] / [Down] → Change setting

Save : To memory remaining credits when rebooting

Clear : Reset to 0 when rebooting

[CATCH] ☀ → Save & Exit

A7 : Play Till Win :

A7 : Play Till Win
↑ ↓ : Change ☀ ->Exit
=YES / NO

Joystick [Up] / [Down] → Change setting

YES : In win game, allow player to play all the time until winning

NO : Only allow player to play by credits even in win game.

[CATCH] ☀ → Save & Exit

A8 : Volume Adjustment:

A8 Volume Adj.		
↑ :+	↓ :-	☀→Exit
=	1~10	

Joystick [Up] / [Down]→ Adjust value

Range : 1~10

[CATCH] ☀→ Save & Exit

A9 : Clamp Start Position:

A9 : Clamp Start	
Start =	At Home / At center
Forward=	1.0 ~5.0 sec
Right=	1.0 ~5.0 sec

Joystick [Right] / [Left]→ Select

Joystick [Up] / [Down]→ Adjust value

The adjustment for seconds of “Forward” and “Right” is only available when it was set “At center”.

[CATCH] ☀→ Save & Exit

A10 Coin Disable/Enable :

A10 : Coin Dis/En	
↑ ↓ :Change	☀ ->Exit
When Game Start	
>> Coin Enable / Coin Disable	

Joystick [Up]/ [Down]→ Change setting

When Game Start to select : Coin Enable / Coin Disable.

[CATCH] ☀→ Save & Exit

A11 Clamp End-P (Position) :

A11 : Clamp End-P (Position)	
↑ ↓ :Change	☀ ->Exit
>> Clamp End-P (Position) Front /Behind	

Joystick [Up]/ [Down]→ Change setting

Clamp End-P(Position) Front / Behind.

[CATCH] ☀→ Save & Exit

3. >B : Clamp Power : (Claw Power / Claw Voltage)

>B1 : Strong-V
>B2 : Middle-V
>B3 : Weak-V
>B4:Mid-V Height

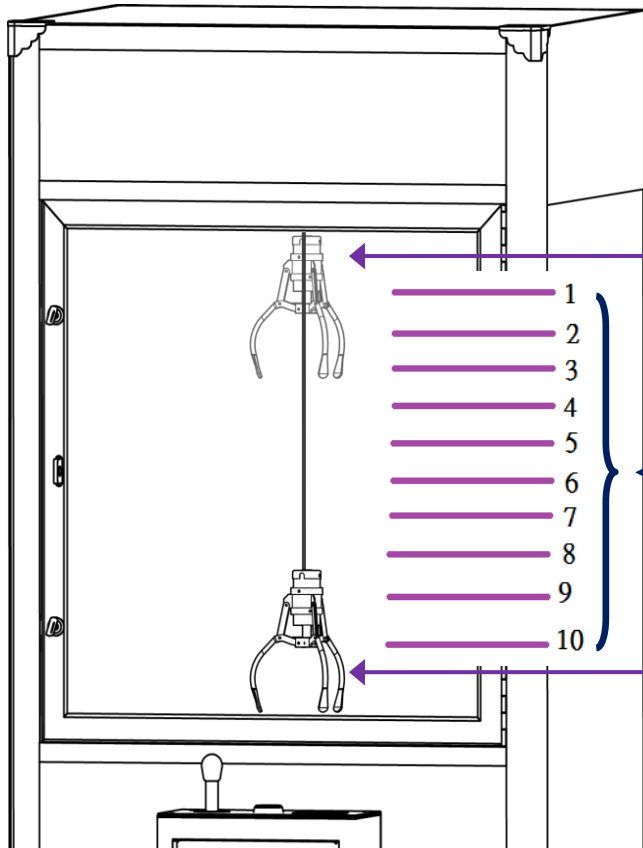

B2 : Weak-V
Low voltage remains for catching:
The voltage remains when claw is
reached top and moving to prize
output hole.

B2 : Middle-V
Middle voltage remains for
catching. The voltage remains
when claw reached setting height
until reached top position.

B1 : Strong-V
High voltage for catching: High
voltage for claw catching in
bottom.

B4 : Mid-V Height
The height for claw catching from
High voltage to Middle voltage. 1
is at the top and 10 is at the
bottom.

B1 : Strong-V :

B1 : Strong-V
20.0V ~ 48.0V
↑ :+ ↓ :- ☀→Exit
= 48.0V

Joystick [Up]/ [Down] → Change setting

Range: 20V~48V

[Press The CATCH Button] ☀ → Save & Exit

It will save the setting and exit automatically if operator doesn't change anything for 30 seconds.

B2 : Middle-V :

B2 : Middle-V
0.0V ~ 48.0V
↑ :+ ↓ :- ☀→Exit
= 20.0V

Joystick [Up]/ [Down] → Change setting

Range: 0V~48V

[Press The CATCH Button] ☀ → Save & Exit

It will save the setting and exit automatically if operator doesn't change anything for 30 seconds.

B3 : Weak-V :

B3 : Weak-V
0.0V ~ 30.0V
↑ :+ ↓ :- ☀→Exit
= 10.0V

Joystick [Up]/ [Down] → Change setting

Range:0V~30V

[Press The CATCH Button] ☀ → Save & Exit

It will save the setting and exit automatically if operator doesn't change anything for 30 seconds.

B4 : Mid-V Height :

B4 : Mid-V Height
1 (HI) ~ 10(LOW)
↑ :+ ↓ :- ☼→Exit
= 5

Joystick [Up]/ [Down] → Change setting

Range:1~10 ,

1 : Highest ; 10 : Lowest

[Press The CATCH Button] ☼ → Save & Exit

1. > C : Accounts :

C : Accounts
C1>Bonus N. Bank
C2>Coin Play Cou.(Play Counter)
C3>Gift Out Cou. (Prize Counter)

C1 : C1:Bonus N. Bank :

(example : 0) ◦

C1 : C1 : Bonus N. Bank
Counter
= 0
"0"= push  -> 2 sec

Bonus N. Bank : the value increase 1 for every play by inserting coins, and will be reset after winning

Joystick → No use

Press [CATCH] once → Exit

Press [CATCH] once for 2 seconds → Reset value & Exit

C2 : Coin Play Counter :

(example : 31) ◦

C2 : Coin Play Cou.(counter)
Counter
= 31
"0"= push  -> 2 sec

Coin Play Counter : the value increase 1 for every play by inserting coins.

Joystick → No use

Press [CATCH] once → Exit

Press [CATCH] once for 2 seconds → Reset value & Exit

C3 : Gift Out counter : (Prize Counter)
(example : 17) ◦

C3 : Gift Out Cou. (prize counter)
Counter
= 17
“0”= push ☀-> 2 sec

Joystick → No use

Press [CATCH] once → Exit

Press [CATCH] once for 2 seconds → Reset value & Exit

2. >D : Play Mode:

>D: Play Mode
>>Business (Game Play Mode)
>>Free Play
>>Machine Test

Joystick [Up] / [Down] → Change setting

> Business : Disable free play mode.

> Free Play : Enable free play mode.

> Machine Test : To enter auto test mode. The mode is for QC purpose of manufacturer only.

[CATCH] ☀ → Save & Exit

3. >E : Motor Speed Adjustment:

>E : Motor Speed
E1>F&B Motor Sp. (Speed)
E2>L&R Motor Sp. (Speed)
E3>U&D Motor Sp. (Speed)
E4>All Speed 100%

E1> Forward & Backward

E2> Left & Right

E3> Up & Down

Joystick [Up] / [Down] → Select items

Joystick [Right] → Enter

Joystick [Left] → Exit

E1 : Forward & Backward Motor Speed Adjustment

E1>F&B Motor Sp. (Speed)
↑ :+ ↓ :- ☀→Test
=100%

Joystick [Up] / [Down] → Adjust value

Range : 30%~100%

30% : Slowest

100% : Fastest

[CATCH] → Save & Enter to test mode

Speed test mode :

E1>F&B Motor Sp. (Speed)
>>Joystick Test
=100% Test

Joystick [Up] / [Down] → To make motor moving forward or backward

[CATCH] ☀ → Exit

E2 : Left & Right Motor Speed Adjustment

E2>L&R Motor Sp. (Speed)
↑ :+ ↓ :- ☀→Test
=80%

Joystick [Up] / [Down] → Adjust value

Range: 30%~100%

30% : Slowest

100% : Fastest

[CATCH] → Save & Enter to test mode

Speed test mode :

E2>L&R Motor Sp. (Speed)
>>Joystick Test
=80% Test

Joystick [Right] / [Left] → To make motor moving left or right

[CATCH] ☀ → Exit

E3 : Up & Down Motor Speed Adjustment

E3>U&D Motor Sp. (Speed)
↑ :+ ↓ :- ☀→Test
=50%

Joystick [Up] / [Down] → Adjust value

Range: 30%~100%

30% : Slowest

100% : Fastest

[CATCH] → Save & Enter to test mode

Speed test mode :

E3>U&D Motor Sp. (Speed)
>>Joystick Test
=50% Test

Joystick [Up] / [Down] → To make claw rising or falling

[CATCH] ☀ → Exit

E4> E4>All Speed 100%

E4>All Speed 100%
>>No -->Exit
>>Yes -->Save

Joystick [Up] / [Down] → No/ Yes ◦

No : Refer to settings.

Yes : Speed of all motors are 100%

[CATCH] ☀ → Save & Exit

4. >F : Test :

F : Test
>>F1 : Gift Sensor
>>F2 : Coin Test

Joystick [Right] → Enter

Joystick [Left] → Exit

>F1 : Gift Sensor test (Prize Sensor Test)

Step 1 :

F1 Gift Sensor Test (Prize Sensor)
>>Sensor VR Adj.
LED=OFF
<< OK >>

Sensor Adjustment: Please adjust the sensor in this test

- (1) Check the LED on sensor. If it is on, make sure that no any obstruction remaining in prize chamber.
- (2) Adjust VR by screwdriver. Turn the VR clockwise to the end (lowest value) and the LED supposes to be off. If not, it is probably caused by sensor failure or improper black sticker inside prize chamber.
- (3) Adjust VR again. Turn it counterclockwise (increase value) until LED is on.
- (4) And turn it clockwise again until LED is off and then turn it clockwise a little more.
- (5) As the adjustment has been done, test sensitivity of the sensor by some items during the game.

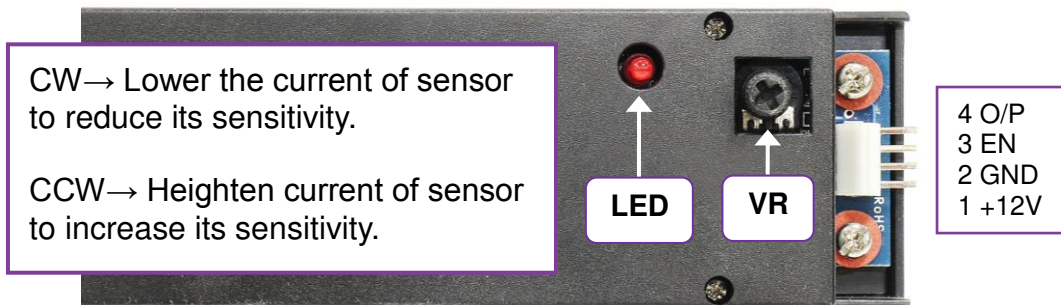

[CATCH] button : Enter to next item

Step 2 :

F1 Gift Sensor test
>>[CATCH]-->Exit
LED=ON
<< OK >>

- (1) Check LED is on or off. If it is off, it may be caused by loosing connector or sensor failure.
- (2) Step 1 and step 2 should be all ok.

>F2 : Coin Test

>F2 : Coin Test
~ Insert Coins ~
Coins=0

- (1) It counts once on "Counter" when inserting a coin. And it will not count on electronic counter.
- (2) Joystick [Left] or [CATCH] → Exit ◦

>G : Default Value

G : Default Value
>NO--> Exit
>YES-> Save & Exit

Joystick [Up] / [Down] → Change setting ◦

>> Select "YES" to make (AA5,A5,A6,A9) settings returning default value.

[Press The CATCH Button] ☀ → Save & Exit

**Default Value :

1. AA5 : Coin Display = PLAY .
2. A5 : Clamp Catch Position= At Bottom .
3. A6 : Coin Save= Clear .
4. A9 : Clamp Start Position = At center .

Section 5:

Wiring Diagram

LCD DIAGRAM

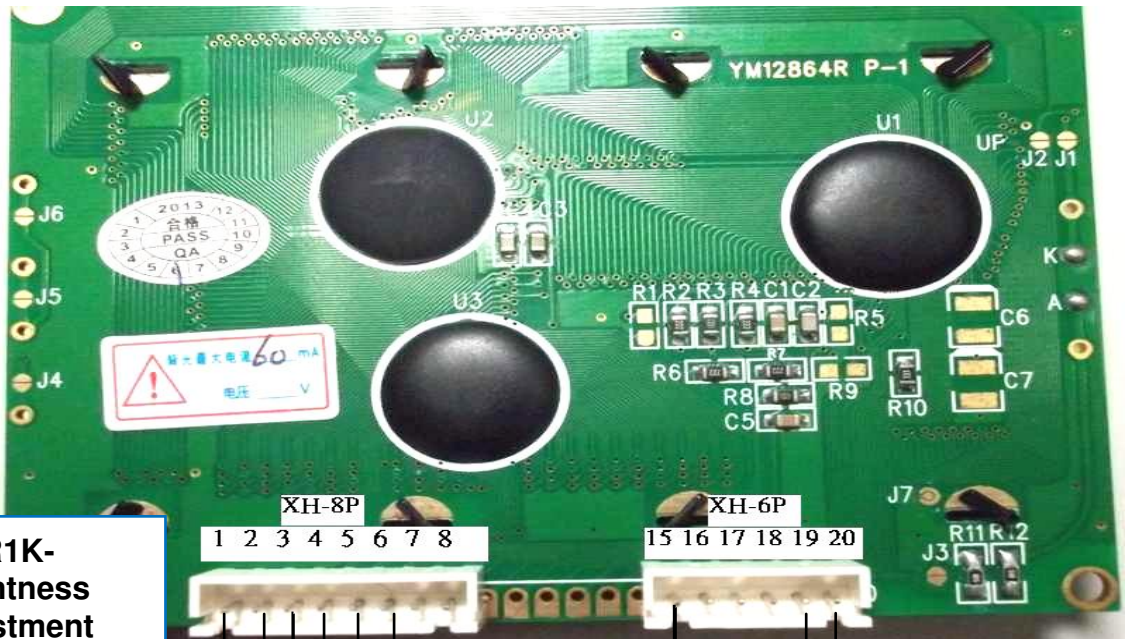

**VR1K-
Brightness
Adjustment**

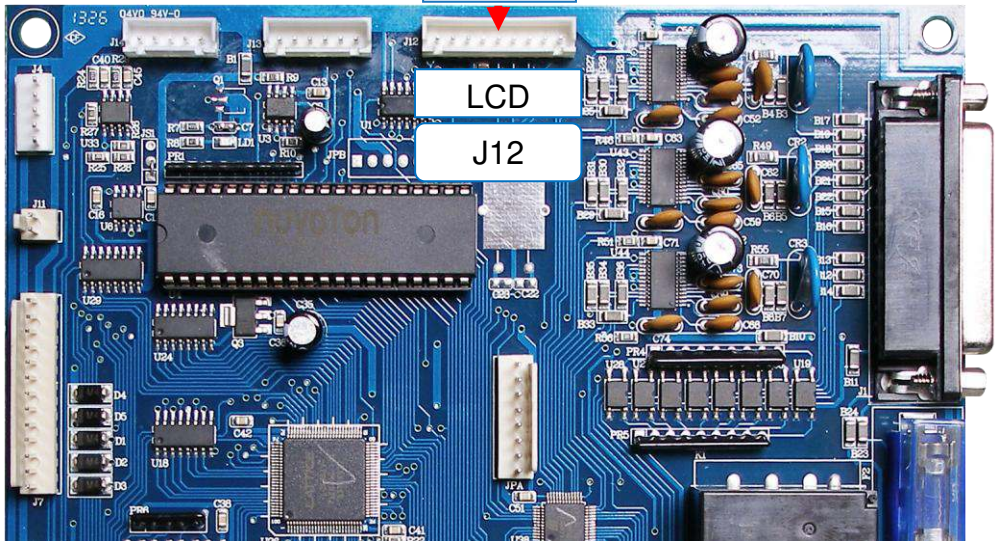
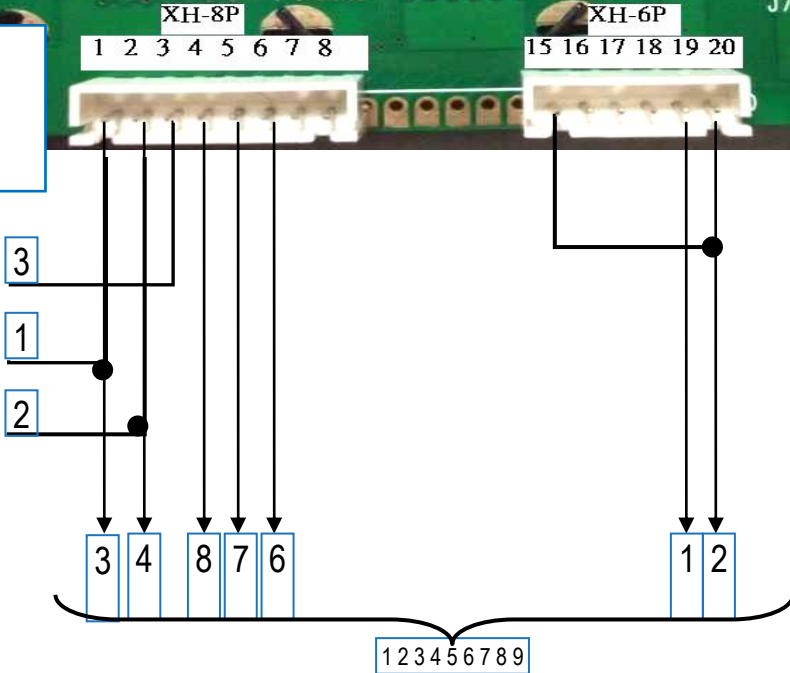
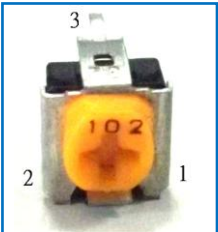
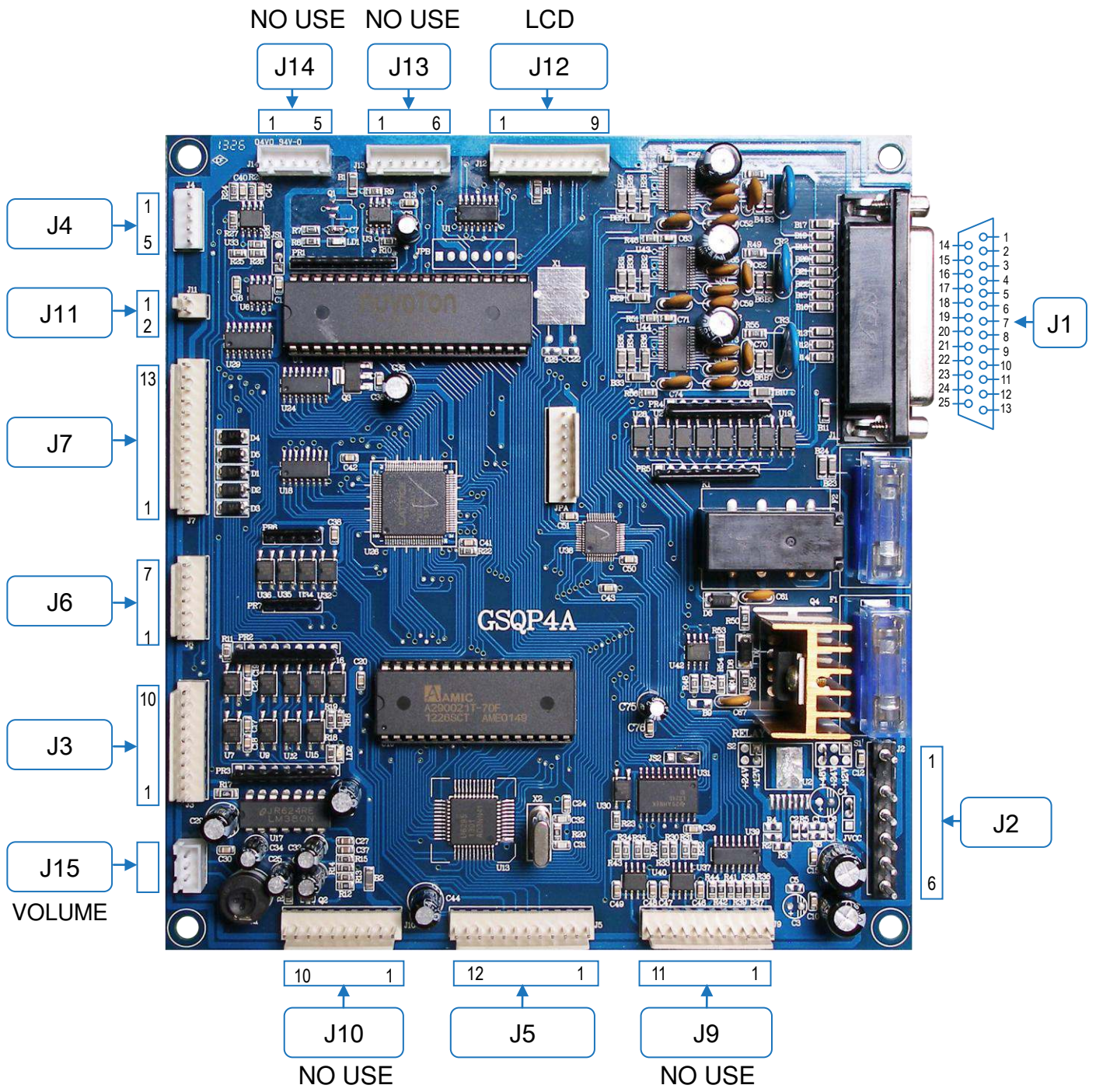

Diagram Of Main Board



J1 (GANTRY)		J2 (POWER SUPPLY)	J3 (SPEAKER & IINPUT)
1. & 14. FORWARD OR BACK MOTOR 2. & 15. LEFT OR RIGHT MOTOR 3. & 16. UP OR DOWN MOTOR 4. & 17. POWER SUPPLY FOR CLAW 5. FRONT LIMIT SWITCH 6. HOME LIMIT SWITCH 7. NC 8. LEFT LIMIT SWITCH 9. TOP LIMIT SWITCH 10. BOTTOM LIMIT SWITCH	11. NC 12. NC 13. NC 18. GND 19. GND 20. GND 21. GND 22. NC 23. NC 24. NC 25. NC	1. GND 2. VCC 3. +24V 4. -48V 5. +48V 6. +12V	1. +12V 2. GND 3. SENSOR OUT 4. SENSOR IN 1 5. FREE PLAY 6. TILT INPUT 7. GND 8. SETTING INPUT 9. SPEAKER OUT 10. GND
J4 (TILT SW)	J5 (COIN SELECTOR & METER)	J6 (JOYSTICK)	J7 (OUTPUT)
1. +12V 2. GND 3. NC 4. TILT SW IN 5. NC	1. GND 2. GND 3. GND 4. COIN SELECTOR 1 SIGNAL 5. COIN SELECTOR 2 SIGNAL 6. OUTPUT RESERVED 7. INPUT RESERVED 8. COIN POWER (V+) 9. OUTPUT METER 10. INPUT METER 1 11. +12V 12. COIN2 /BILL ACCEPTOR	1. CATCH BUTTON 2. RESERVED 3. LEFT 4. RIGHT 5. BACK 6. FORWARD 7. GND	1. LED LIGHT BAR 1 2. LED LIGHT BAR 2 3. COIN2 METER 4. BUTTON LAMP 5. +12V 6. NC 7. NC 8. NC 9. NC 10. NC 11. NC 12. NC 13. +5V
J11 (GND)	J12 (LCD)	J15 (VR)	
1. GND 2. GND	3. ~9. LCD DISPLAY	1~3 VOLUME VR-10K	

Section 6:

Troubleshooting

Error Codes

NO.	ERROR ITEM	SOLUTION
01	COIN COUNTER 1 ERROR	(1) Check wiring (2) Replace counter
02	COIN COUNTER 2 ERROR	(1) Check wiring (2) Replace counter
03	PRIZE COUNTER	(1) Check wiring (2) Replace counter
04	COIN SELECTOR 1 ERROR	Check NC/NO SW on coin selector, it should be NO
05	COIN SELECTOR 2 ERROR	Check NC/NO SW on coin selector, it should be NO
06	PRIZE SENSOR ERROR	(1) Adjust sensor VR (2) Replace sensor
07	PCB DATA ERROR	Enter to setting menu to re-set all values
08	PCB MEMORY ERROR	Replace PCB
10	TICKET (CARD OR CAPSULE) OUTPUT ERROR	Refill tickets (cards or capsules)
11	MOTOR UP ERROR	(1) Check UP SW (2) Check fuse "F1" on PCB
12	MOTOR DOWN ERROR	(1) Check DOWN SW. (2) Check fuse "F1" on PCB
13	MOTOR LEFT ERROR	(1) Check LEFT SW. (2) Check fuse "F1" on PCB
14	MOTOR RIGHT ERROR	Check fuse "F1" on PCB
15	MOTOR FORWARD ERROR	(1) Check FORWARD SW. (2) Check fuse "F1" on PCB
16	MOTOR BACKWARD ERROR	(1) Check BACKWARD SW. (2) Check fuse "F1" on PCB

Section 7:

Enclosure

1 Warranty

Please be prepared to provide the following information for place a warranty request :

- (1) The Machine type or product number.
- (2) Serial Number of Game or Commercial Invoice of Sale.
- (3) A Detailed Description of the Equipment Fault Symptoms.

2 Maintenance

Items	Maintenance	Period	Notice
Interior clean	Use dry cloth with normal detergent to clean	Depend on machine situation	1.Do not use strong acid or corrosive detergent to clean 2. Do not use water to wash it directly to avoid any electronic damage
Exterior clean	Use dry cloth with normal detergent to clean	Depend on machine situation	1.Do not use strong acid or corrosive detergent to clean 2. Do not use water to wash it directly to avoid any electronic damage
Glass clean	Use dry cloth with normal detergent to clean	Depend on machine situation	1.Do not use strong acid or corrosive detergent to clean 2. Do not use water to wash it directly to avoid any electronic damage
Gantry clean	Use dry cloth to clean	Depend on machine situation	1.Do not use strong acid or corrosive detergent to clean 2. Do not use water to wash it directly to avoid any electronic damage
Check LEDs	Check LED Lights	monthly	Change LEDs as necessary
Check power cord	Check power cord	weekly	Do not touch power cord by hand directly to avoid electric shock

TOY CHEST

CRANE MANUAL

INCLUDES

PIRATE CHEST

HOT DIAMOND

LITTLE DIAMOND

MP4 CRANE

CANDY CRANE

CANDY HOUSE



SMART
INDUSTRIES CORP., MFG.
1901 Bell Avenue Suite 12
Des Moines, Iowa 50315 USA
(515) 265-9900 (800) 553-2442
FAX (515) 265-3148
www.smartind.com

Rev. L 10/09/14

Adjusting the Claw Strength

The Toy Chest Crane is designed to control 3 levels of voltage to the claw. When enough coins are inserted to play a game, use the joystick to move the crane to the desired position. Press the "catch" button to drop the claw. When the claw is dropped down and touches a prize or the play field the claw will close and return back up. The "catch" button may also be pressed a second time to close the claw at a desired position after it is dropped.

At the time the claw is initially closed and begins to rise, the voltage to the claw is at the first voltage setting, which is set by the **VR1** potentiometer, also labeled **HIGH**, on the Claw Adjustment Controller Board.

The second claw voltage range, which is set by the **VR2** potentiometer, also labeled **MIDDLE**, on the Claw Adjustment Controller Board, appears while the claw is rising up, 10 to 15 cm near the top.

When the claw reaches the top, the voltage to the claw is at the third voltage setting, which is set by the **VR3** potentiometer, also labeled **LOW**, on the Claw Adjustment Controller Board. The claw will remain at this voltage until the crane moves to the home position and the claw opens.

CLAW ADJUSTMENT CONTROLLER BOARD

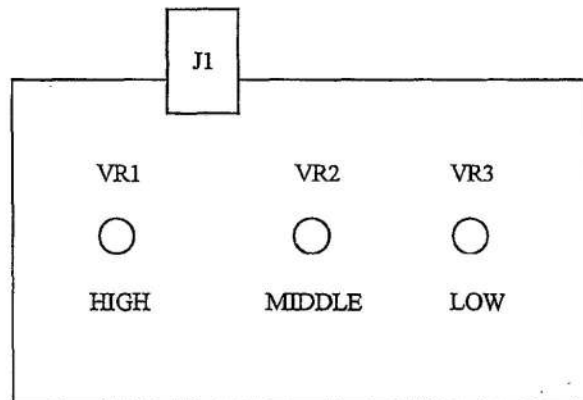

This board is located inside of the cabinet of the console, behind the analog voltmeter.

To set the three different claw voltages, use the DIP Switch settings SW4 #3, #4, and #5 to make the adjustments.

Adjusting the Claw Strength { continued }

Using the Claw Voltage Adjustment Mode:

Setting the HIGH voltage setting

1. Set DIP Switch SW4 #3 and #4 to the OFF position and SW4 #5 to the ON position.
2. Reset the game and then claw will remain closed.
3. At this time the analog meter in the game will indicate the voltage to the claw that will be used for the 1st voltage setting.
4. This can be adjusted by turning **VR1** on the Claw Adjustment Controller Board. This is the voltage setting the claw will have when it initially closes and begins to rise.

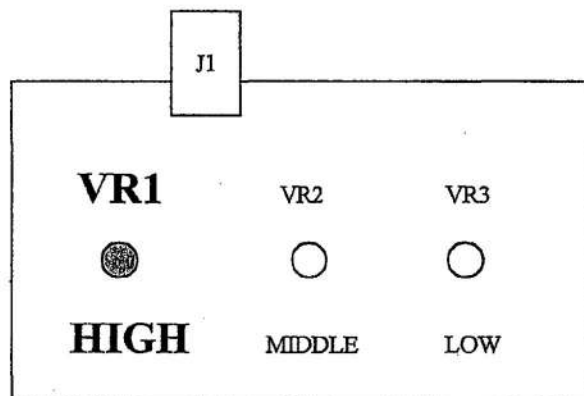

Turning **VR1** clockwise will increase the HIGH voltage setting.

Turning **VR1** counterclockwise will decrease the HIGH voltage setting.

NOTE: The factory setting for the HIGH setting is 45 VDC.

5. When the voltage is adjusted to the desired level, turn OFF SW4 #5 and reset the game.

NOTE:

When the final claw adjustment is made, set DIP Switch SW4 #3, #4, and SW4 #5 to the OFF position and reset the game to return to game play mode.

Adjusting the Claw Strength { continued }

Setting the MIDDLE voltage setting

1. Set DIP Switch SW4 #3 and #5 to the OFF position and SW4 #4 to the ON position
2. Reset the game and then claw will remain closed.
3. At this time the analog meter in the game will indicate the voltage to the claw that will be used for the 2nd voltage setting.
4. This can be adjusted by turning VR2 on the Claw Adjustment Controller Board. This is the voltage setting the claw will have while the claw is rising up 10 to 15 cm near the top.

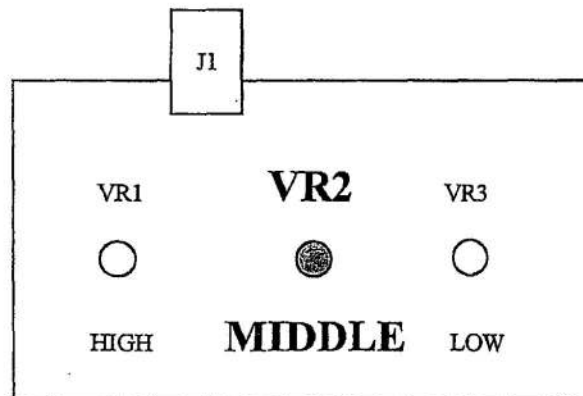

Turning **VR2** clockwise will increase the MIDDLE voltage setting.

Turning **VR2** counterclockwise will decrease the MIDDLE voltage setting.

NOTE: The factory setting for the MIDDLE setting is 30 VDC

5. When the voltage is adjusted to the desired level, turn OFF SW4 #4 and reset the game.

NOTE:

When the final claw adjustment is made, set DIP Switch SW4 #3, #4, and SW4 #5 to the OFF position and reset the game to return to game play mode.

Adjusting the Claw Strength { continued }

Setting the LOW voltage setting

1. Set DIP Switch SW4 #4 and #5 to the OFF position and SW4 #3 to the ON position.
2. Reset the game and then claw will remain closed.
3. At this time the analog meter in the game will indicate the voltage to the claw that will be used for the 3rd voltage setting.
4. This can be adjusted by turning VR3 on the Claw Adjustment Controller Board. This is the voltage setting the claw will have when it reaches the top and moves to the home position.

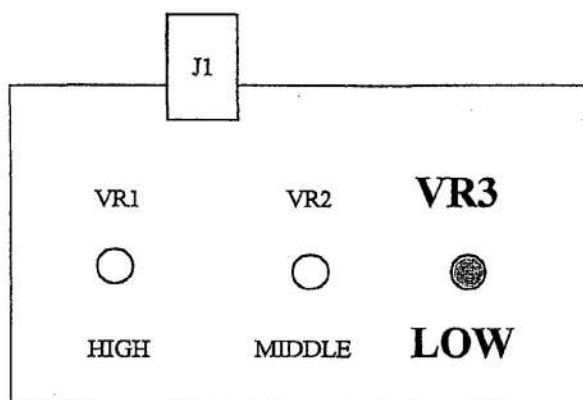

Turning **VR3** clockwise will increase the LOW voltage setting.

Turning **VR3** counterclockwise will decrease the LOW voltage setting.

NOTE: The factory setting for the LOW setting is 15 VDC

5. When the voltage is adjusted to the desired level, turn OFF SW4 #3 and reset the game.

NOTE:

When the final claw adjustment is made, set DIP Switch SW4 #3, #4, and SW4 #5 to the OFF position and reset the game to return to game play mode.

Adjusting the Claw Strength { continued }

Claw Voltage Reading during non-payout time:

When the claw goes down and closes, the claw strength will be at the 1st voltage setting, then converting to the 2nd voltage setting, and finally the 3rd voltage setting.

Example

1st Voltage Setting 45VDC (set by the VR1 potentiometer)
2nd Voltage Range 30VDC (set by the VR2 potentiometer)
3rd Voltage Range 15VDC (set by the VR3 potentiometer)

Claw Voltage Reading during payout time:

When the claw goes down and closes, the claw strength will be at the 1st voltage setting, then converting to the 2nd voltage setting, and back to the 1st voltage setting.

Example

1st Voltage Setting 45VDC (set by the VR1 potentiometer)
2nd Voltage Range 30 VDC (set by the VR2 potentiometer)
1st Voltage Range 45 VDC (set by the VR1 potentiometer)

Analog Meter

Claw Voltage Analog Meter

The analog meter in the game will indicate the voltage to the claw. The analog meter can be used to monitor the claw voltage during game play and during the Claw Voltage Test Mode.

Mechanical Meters

Coin IN Meter

The Coin IN Meter will increment one time for each coin inserted in the coin mech.

DBA IN Meter

The DBA IN Meter will increment four times for each dollar inserted in the DBA.

Prize OUT Meter

The Prize OUT Meter will increment one time when a prize is detected.

DIP SWITCH SETTING DESCRIPTIONS

SWITCH 1

This bank of DIP Switches is used to configure the Win Rate payout.
See the "Standard Win Rate" chart for more information.

SWITCH 2

CENTERING

If SW2 #1 is ON, the crane will move to the center position when game play begins.
If SW2 #1 is OFF, the crane will remain over the prize chute when game play begins.

DISPLAY

If SW2 #2 is OFF, the display will show the number of CREDITS (COINS) inserted.
If SW2 #2 is ON, the display will show the number of PLAYS AVAILABLE.

WARNING SOUND

If SW2 #3 is ON, an alarm sound will be heard when an error has been detected.
If SW2 #3 is OFF, the alarm sound will not be heard when an error has been detected.

WIN RATE MULTIPLIER

If SW2 #4 is OFF, the Win Rate will be Multiplied by 1.
If SW2 #4 is ON, the Win Rate will be Multiplied by 10.

The Original Win Rate Maximum Setting is 1 in 121
If you set DIP SW 2 #4 ON, you get 10 times more, $121 \times 10 \text{ times} = 1210$

Dip SW 2 #4 ON - Win Rate x 10 times, so the highest payout is 1 in 1210 times.

In addition, when you program the Win Rate, after rebooting the game,
the Credit timer Display will show the Value you set.

Example:

If the Win Rate is set to 1200 times;

When the Power is turned ON, the Credit Timer Display will show the following:

00 for 0.5 seconds; Then 12 for 0.8 seconds; Then 00 for 0.8 seconds;
Then countdown $\rightarrow 99 \rightarrow 88 \rightarrow 77 \rightarrow \dots$ etc.

The 12 on the Credit Timer Display indicates your Win Rate setting.

FREE PLAY

If SW2 #8 is ON, the game will play for free. Coins will not need to be inserted to play the game.
If SW2 #8 is OFF, free play is disabled. Coins will need to be inserted to play the game.

SWITCH 3

COIN MECH 1

DIP Switch SW3 #1 will set the number of credits per coin

BILL ACCEPTOR

DIP Switch SW3 #2 will set the number of credits per DBA pulse

4 CREDITS FOR 1 PLAY

If DIP Switch SW3 #3 is ON, the game will require 4 credits for 1 play

CREDITS TO PLAY

DIP Switch SW3 #4, #5, and #6 will set the number of credits per game

GAME TIME

DIP Switch SW3 #7 and #8 set the amount of time to play each game

SWITCH 4

COIN MEMORY

If SW4 #1 is ON, any credits on the game will CLEAR to zero credits when the game is reset.
If SW4 #1 is OFF, any credits on the game will be SAVED when the game is reset.

* FACTORY SETTING

The DIP Switch SW4 #2 MUST remain in the ON position for the crane head to find the home position properly.

DO NOT CHANGE THIS SETTING.

** CLAW VOLTAGE TEST MODE

See the "Adjusting the Claw Strength" pages for more information.

ATTRACT MODE

If SW4 #6 is OFF, the attract mode will be ENABLED.
If SW4 #6 is ON, the attract mode will be DISABLED.

*** PRIZE SENSOR TEST MODE

With SW4 #7 ON, the display will show "11". LD4 on the CPU will be OFF. When the prize detection is blocked, LD4 on the CPU will be lit up. Turn SW4 #7 OFF when done testing.

PLAY 'TIL YOU WIN

If SW4 #8 is ON, the game will continue to play on the same credit until a prize is won.
If SW4 #8 is OFF, the Play 'Til You Win mode will be DISABLED.

STANDARD WIN RATE

DIP SWITCH SETTINGS

WIN RATE VALUE CHART: For SWITCH 1

	1	2	3	4	5	6	7	8
ADDS 1 PLAY TO THE TOTAL	<u>ON</u>	OFF	OFF	OFF	OFF	OFF	OFF	OFF
ADDS 2 PLAYS TO THE TOTAL	OFF	<u>ON</u>	OFF	OFF	OFF	OFF	OFF	OFF
ADDS 3 PLAYS TO THE TOTAL	OFF	OFF	<u>ON</u>	OFF	OFF	OFF	OFF	OFF
ADDS 5 PLAYS TO THE TOTAL	OFF	OFF	OFF	<u>ON</u>	OFF	OFF	OFF	OFF
ADDS 10 PLAYS TO THE TOTAL	OFF	OFF	OFF	OFF	<u>ON</u>	OFF	OFF	OFF
ADDS 20 PLAYS TO THE TOTAL	OFF	OFF	OFF	OFF	OFF	<u>ON</u>	OFF	OFF
ADDS 30 PLAYS TO THE TOTAL	OFF	OFF	OFF	OFF	OFF	OFF	<u>ON</u>	OFF
ADDS 50 PLAYS TO THE TOTAL	OFF	OFF	OFF	OFF	OFF	OFF	OFF	<u>ON</u>

The WIN RATE of 1 out of " X " Plays can be calculated by "Adding the TOTAL VALUE of each DIP Switch turned ON"

FACTORY DEFAULT SETTING is set at 1 out of 10 times. To set it to the factory default setting, turn SWITCH 1 # 5 ON and the remaining switches OFF.

EXAMPLE:

- FOR A WIN EVERY 59 TIMES, SET SW1 #1, #3, #4, #6, #7 to the ON position

$$\text{SW1 \#1} = 1 \quad \text{SW1 \#3} = 3 \quad \text{SW1 \#4} = 5 \quad \text{SW1 \#6} = 20 \quad \text{SW1 \#7} = 30$$

$$1 + 3 + 5 + 20 + 30 = 59$$

SWITCH 1	1	2	3	4	5	6	7	8
To Win 1 Out Of 59 TIMES	<u>ON</u>	OFF	<u>ON</u>	<u>ON</u>	OFF	<u>ON</u>	<u>ON</u>	OFF

EXAMPLE:

- FOR A WIN EVERY 40 TIMES, SET SW1 #5 and #7 to the ON position

$$\text{SW1 \#5} = 10 \quad \text{SW1 \#7} = 30$$

$$10 + 30 = 40$$

SWITCH 1	1	2	3	4	5	6	7	8
To Win 1 Out Of 40 TIMES	OFF	OFF	OFF	OFF	<u>ON</u>	OFF	<u>ON</u>	OFF

STANDARD WIN RATE

DIP SWITCH SETTINGS

SWITCH 1	1	2	3	4	5	6	7	8
To Win 1 Out Of 1 TIME	<u>ON</u>	OFF	OFF	OFF	OFF	OFF	OFF	OFF
To Win 1 Out Of 2 TIMES	OFF	<u>ON</u>	OFF	OFF	OFF	OFF	OFF	OFF
To Win 1 Out Of 3 TIMES	OFF	OFF	<u>ON</u>	OFF	OFF	OFF	OFF	OFF
To Win 1 Out Of 4 TIMES	<u>ON</u>	OFF	<u>ON</u>	OFF	OFF	OFF	OFF	OFF
To Win 1 Out Of 5 TIMES	OFF	OFF	OFF	<u>ON</u>	OFF	OFF	OFF	OFF
To Win 1 Out Of 6 TIMES	<u>ON</u>	OFF	OFF	<u>ON</u>	OFF	OFF	OFF	OFF
To Win 1 Out Of 7 TIMES	OFF	<u>ON</u>	OFF	<u>ON</u>	OFF	OFF	OFF	OFF
To Win 1 Out Of 8 TIMES	OFF	OFF	<u>ON</u>	<u>ON</u>	OFF	OFF	OFF	OFF
To Win 1 Out Of 9 TIMES	<u>ON</u>	OFF	<u>ON</u>	<u>ON</u>	OFF	OFF	OFF	OFF
To Win 1 Out Of 10 TIMES	OFF	OFF	OFF	OFF	<u>ON</u>	OFF	OFF	OFF
To Win 1 Out Of 11 TIMES	<u>ON</u>	OFF	OFF	OFF	<u>ON</u>	OFF	OFF	OFF
To Win 1 Out Of 12 TIMES	OFF	<u>ON</u>	OFF	OFF	<u>ON</u>	OFF	OFF	OFF
To Win 1 Out Of 13 TIMES	OFF	OFF	<u>ON</u>	OFF	<u>ON</u>	OFF	OFF	OFF
To Win 1 Out Of 14 TIMES	<u>ON</u>	OFF	<u>ON</u>	OFF	<u>ON</u>	OFF	OFF	OFF
To Win 1 Out Of 15 TIMES	OFF	OFF	OFF	<u>ON</u>	<u>ON</u>	OFF	OFF	OFF
To Win 1 Out Of 16 TIMES	<u>ON</u>	OFF	OFF	<u>ON</u>	<u>ON</u>	OFF	OFF	OFF
To Win 1 Out Of 17 TIMES	OFF	<u>ON</u>	OFF	<u>ON</u>	<u>ON</u>	OFF	OFF	OFF
To Win 1 Out Of 18 TIMES	OFF	OFF	<u>ON</u>	<u>ON</u>	<u>ON</u>	OFF	OFF	OFF
To Win 1 Out Of 19 TIMES	<u>ON</u>	OFF	<u>ON</u>	<u>ON</u>	<u>ON</u>	OFF	OFF	OFF
To Win 1 Out Of 20 TIMES	OFF	OFF	OFF	OFF	OFF	<u>ON</u>	OFF	OFF
To Win 1 Out Of 21 TIMES	<u>ON</u>	OFF	OFF	OFF	OFF	<u>ON</u>	OFF	OFF
To Win 1 Out Of 22 TIMES	OFF	<u>ON</u>	OFF	OFF	OFF	<u>ON</u>	OFF	OFF
To Win 1 Out Of 23 TIMES	OFF	OFF	<u>ON</u>	OFF	OFF	<u>ON</u>	OFF	OFF
To Win 1 Out Of 24 TIMES	<u>ON</u>	OFF	<u>ON</u>	OFF	OFF	<u>ON</u>	OFF	OFF
To Win 1 Out Of 25 TIMES	OFF	OFF	OFF	<u>ON</u>	OFF	<u>ON</u>	OFF	OFF
To Win 1 Out Of 26 TIMES	<u>ON</u>	OFF	OFF	<u>ON</u>	OFF	<u>ON</u>	OFF	OFF
To Win 1 Out Of 27 TIMES	OFF	<u>ON</u>	OFF	<u>ON</u>	OFF	<u>ON</u>	OFF	OFF
To Win 1 Out Of 28 TIMES	OFF	OFF	<u>ON</u>	<u>ON</u>	OFF	<u>ON</u>	OFF	OFF
To Win 1 Out Of 29 TIMES	<u>ON</u>	OFF	<u>ON</u>	<u>ON</u>	OFF	<u>ON</u>	OFF	OFF
To Win 1 Out Of 30 TIMES	OFF	OFF	OFF	OFF	OFF	OFF	<u>ON</u>	OFF

Component Board Block Wiring Diagram

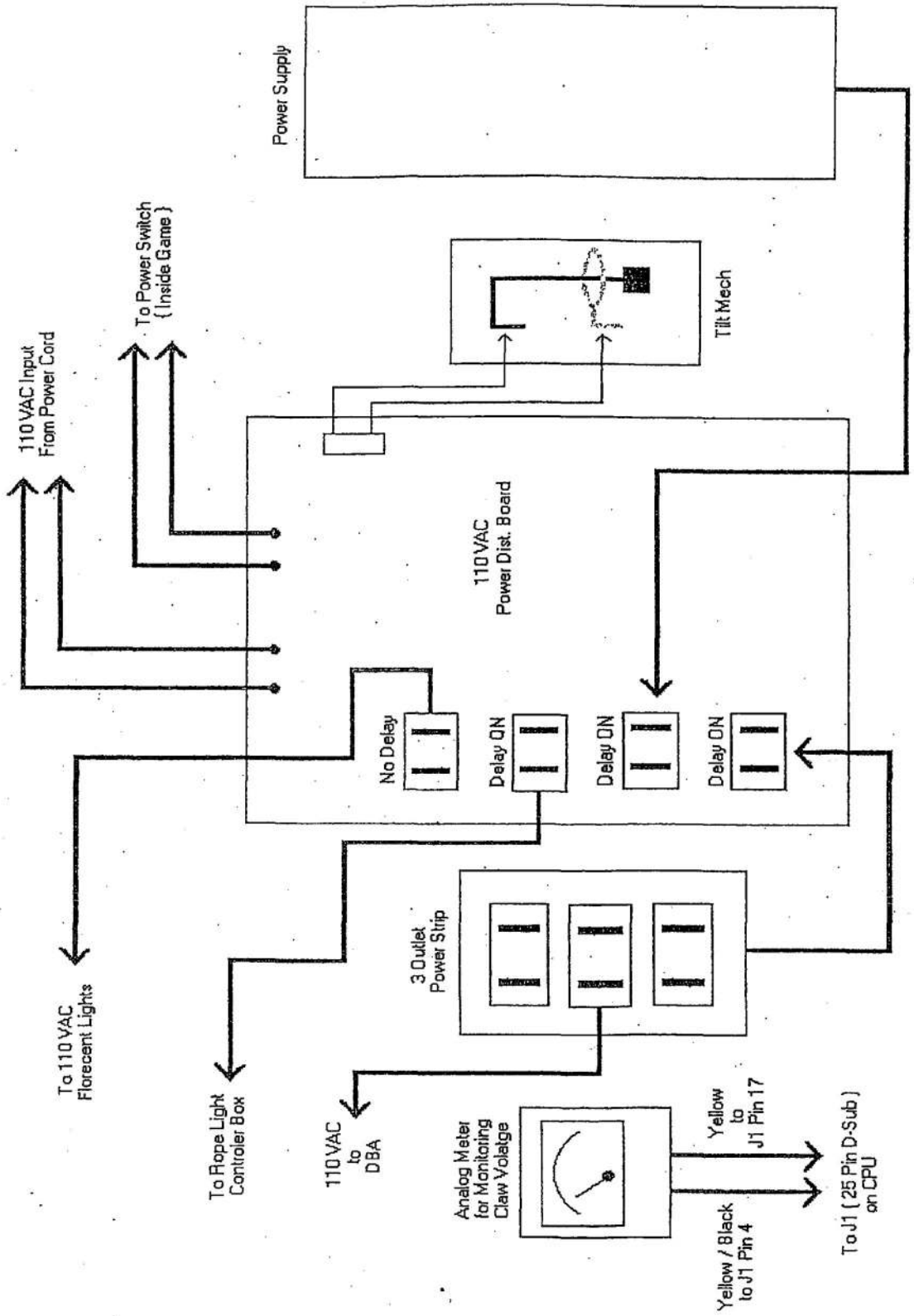

Prize Sensor Board

The prize sensor should ONLY be adjusted when the following occurs:

1. The sensor is faulty.
2. The sensor does NOT detect the merchandise.
3. The sensor ALWAYS detects the merchandise.

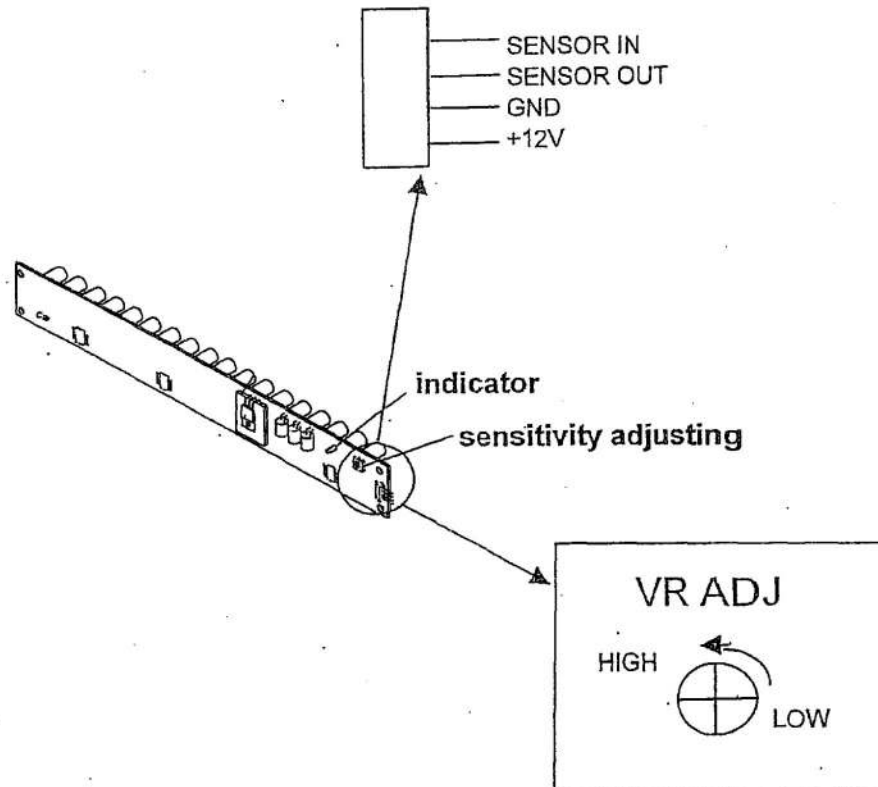

Prize Sensor Adjustment Procedure:

1. Set DIP Switch SW4 #7 to the ON position and reboot the game.
2. The sensor is ready for adjustment when the display shows 11.
3. The LED indicator should be OFF.
4. Turn the potentiometer on the sensor board fully clockwise to the lowest setting. The LED indicator should still be OFF.
5. SLOWLY turn the potentiometer *counterclockwise* until the LED indicator is ON.
6. Then VERY SLOWLY turn the potentiometer clockwise until the LED indicator is OFF.
7. Drop merchandise through the prize chute to determine if the sensors will detect the prize.
8. When the sensor is *properly adjusted*, set DIP Switch SW4 #7 to the OFF position and reboot the game.

Model P2040 Power Supply Diagram

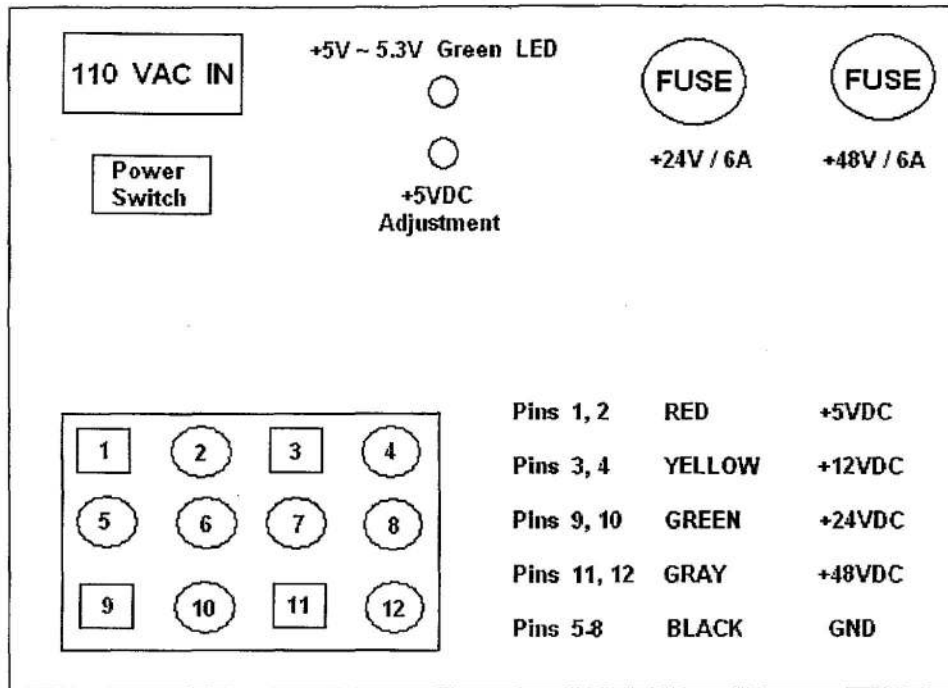

Power Supply Amp Ratings :

+5 VDC at 12 Amps +12 VDC at 6 Amps +24 VDC at 6 Amps +48 VDC at 6 Amps

TOTAL MAX POWER 280 WATTS

Adjusting the Power Supply Voltages :

Adjusting the Potentiometer

Adjusting the Potentiometer on the Power Supply will allow changes in the +5 VDC output. This is to be checked between either +5 VDC pin and ground.

Turning it Counterclockwise will **Decrease** the voltage.

Turning it Clockwise will **Increase** the voltage.

The adjustment range is approximately between +4.8 VDC and +5.6 VDC.

The manufacture setting is +5.25 VDC.

Adjusting the +5 VDC also effects the +12 VDC and the +24 VDC. The +12 VDC range is approximately between +11.3 VDC and +13.3 VDC. The +24 VDC range is approximately between +21.5 VDC and +25.0 VDC.

10 AMP CPU BOARD DIAGRAM

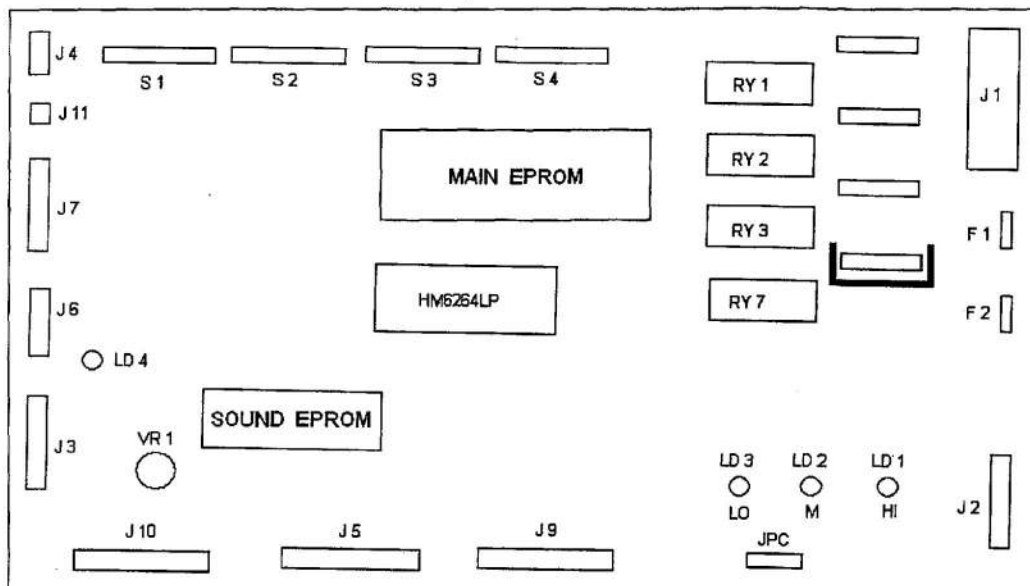

CONNECTORS

See the CPU Wiring Pinout pages for more information.

POTENTIOMETERS

VR1 on the CPU board is used to control the Volume of the game. Turning the potentiometer clockwise will increase the volume. Turning the potentiometer counterclockwise will decrease the volume.

VR1, VR2, and VR3 on the CLAW ADJUSTMENT CONTROL BOARD are used to control the Claw Strength. See the Adjusting the Claw Strength pages for more information.

LEDs

There are four LEDs on this board. LD1 will light when the claw is at the First Voltage Setting. When the claw is at the Second Voltage Setting, LD1 will go off and LD2 will light. When the claw is at the Third Voltage Setting, LD2 will go off and LD3 will light and go off when the crane is in the home position. LD4 will light when the prize detection optics are blocked or when a prize is won.

FUSES

The F1 fuse is a 3 Amp fast blow mini fuse. It is used to protect the up / down motor on the crane.

The F2 fuse is a 3 Amp fast blow mini fuse. It is used to protect the claw solenoid on the crane.

DIP SWITCHES

There are 4 banks of DIP switches on this board. They are labeled S1, S2, S3, and S4. To enable the switch or turn it to the ON position, slide the desired switch up. To disable the switch or turn it OFF, slide the desired switch down. See the DIP SWITCH SETTINGS charts for function of each bank of switches.

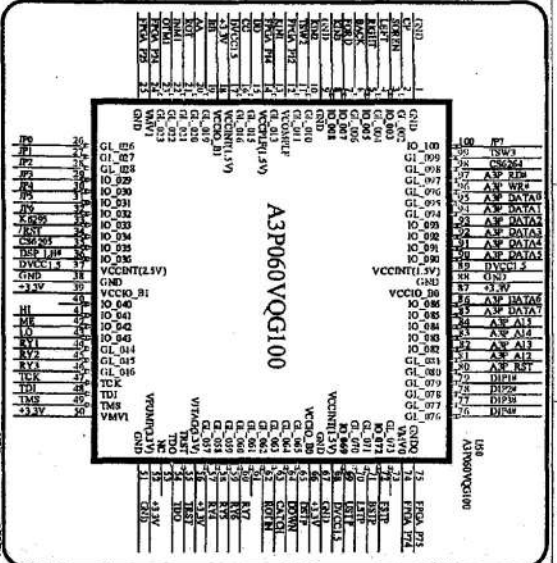

A3P060VQG100-PR11 & PR12 can not be listed in A3P060VQG100-PR11 & PR12 must be listed in 002

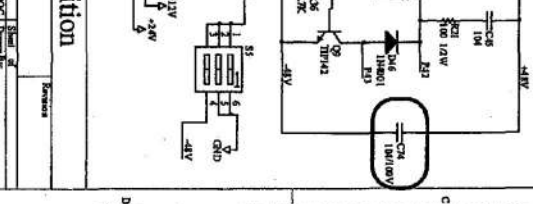
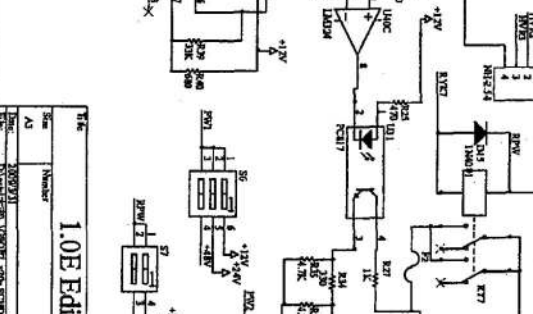
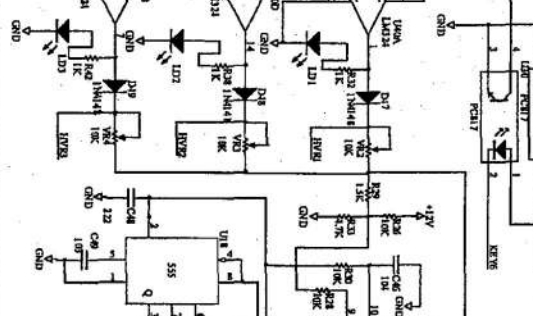
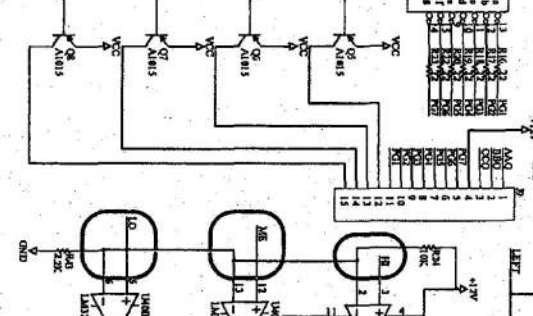
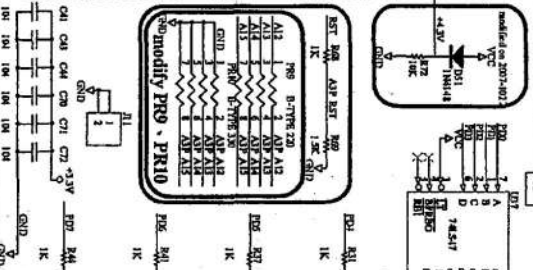
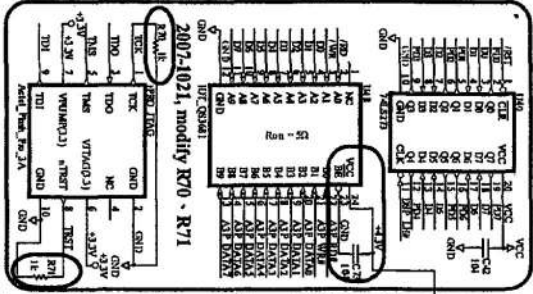

1.0E Edition

20071021

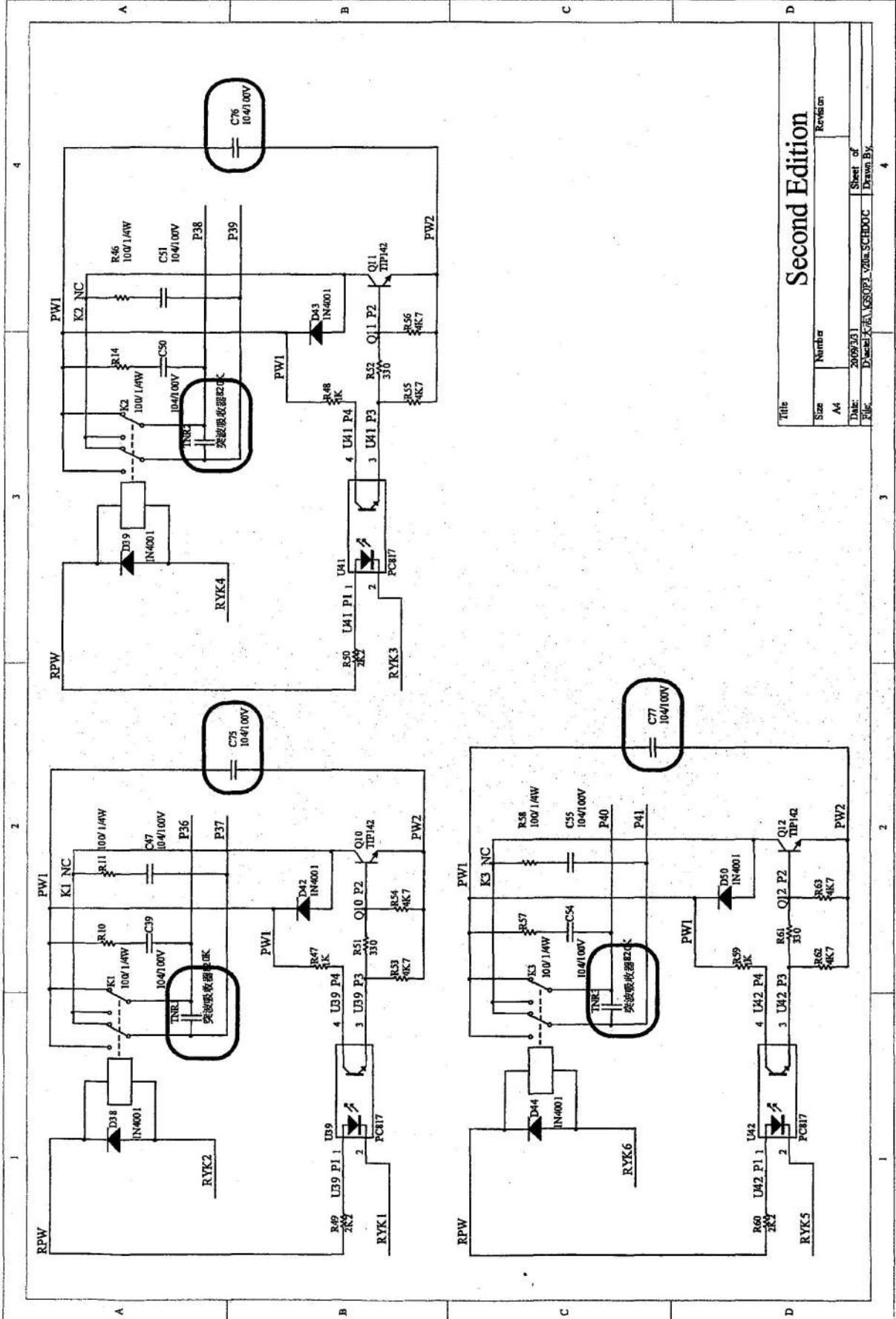

Title		Revision	
Size	Number		
A4			
Date:	2009/3/1	Sheet of	4
File:	D:\2009\3\1\2009031\2009031.SCHDOC	Drawn By:	

Second Edition

TOY CHEST WIRING DIAGRAM

NOTE THE VARIOUS POSITIONS OF PIN 1 ON THE CONNECTORS

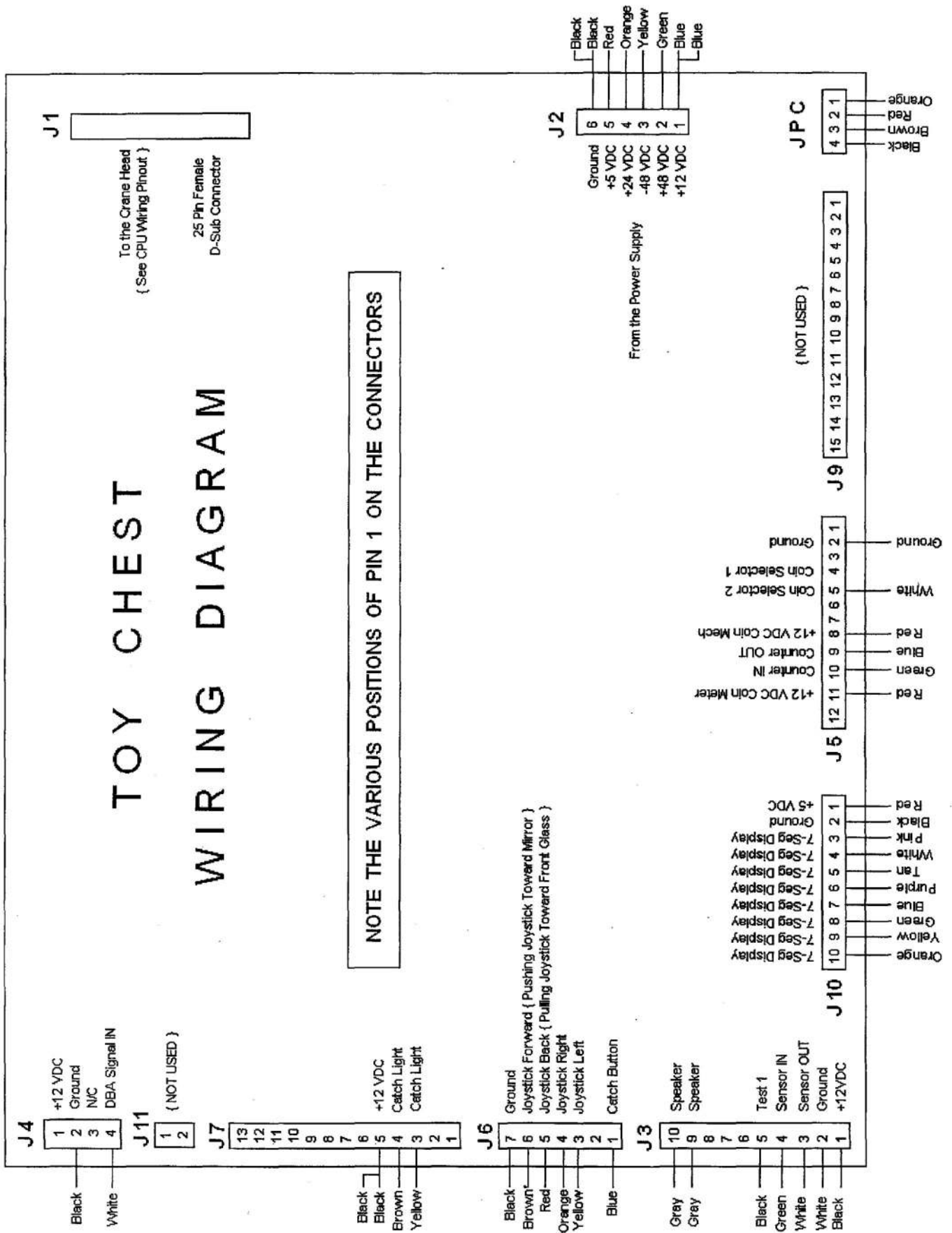

CPU Wiring Pinout

J2 : Power Connector

- | | |
|------------|---------------|
| 1. Ground | (Black) x 2 |
| 2. +5 VDC | (Red) |
| 3. +24 V | (Orange) |
| 4. - 48 V | (Yellow) |
| 5. + 48 V | (Green) |
| 6. +12 VDC | (Blue) x 2 |

J3 : Speaker & Sensor Connector

- | | |
|---------------|-----------|
| 1. +12 VDC | |
| 2. Ground | (Black) |
| 3. Sensor OUT | (White) |
| 4. Sensor IN | (Green) |
| 5. Test 1 | (Black) |
| 6. Test 2 | |
| 7. N/C | |
| 8. N/C | |
| 9. Speaker | (Gray) |
| 10. Speaker | (Gray) |

J5 : Coin Mech., Rotary Motor Control Counter

- | | |
|--------------------------------|-----------|
| 1. Ground | |
| 2. Ground | (Black) |
| 3. Ground | |
| 4. Coin Selector 1 | |
| 5. Coin Selector 2 | (White) |
| 6. Future Use | |
| 7. Future Use | |
| 8. +12 VDC for Coin Selector 1 | (Red) |
| 9. Counter Out | (Blue) |
| 10. Counter In | (Green) |
| 11. Counter Power +12 VDC | (Red) |
| 12. Key | |

J4 : 4 Pin Connector

- | | |
|------------------|-----------|
| 1. +12 VDC | |
| 2. Ground | (Black) |
| 3. N/C | |
| 4. DBA Signal IN | (White) |

CPU Wiring Pinout { continued }

J6 : Joystick & Catch Button

1. Catch Button (Blue) - 1st press = Drop Claw 2nd press = Close Claw
2. Down N/C
3. Left (Yellow)
4. Right (Orange)
5. Back (Red) - Pulling joystick toward the Front Glass
6. Forward (Brown) - Pushing joystick toward the Mirror
7. Ground (Black)

J7 : Display Connector

1. Future Use
2. Future Use
3. Catch Light (Yellow)
4. Catch Light (Brown)
5. +12 VCD (Black) x 2
6. Future Use
7. Future Use
8. Future Use
9. Future Use
10. Future Use
11. Future Use
12. Future Use
13. + 5 VCD

J10 : Display Connector

1. + 5 VDC (Red)
2. Ground (Black)
3. 7-Seg Display (Pink)
4. 7-Seg Display (White)
5. 7-Seg Display (Tan)
6. 7-Seg Display (Purple)
7. 7-Seg Display (Blue)
8. 7-Seg Display (Green)
9. 7-Seg Display (Yellow)
10. 7-Seg Display (Orange)

JPC : To Claw Strength Adjustment Board

1. Ground (Black)
2. Low Claw Setting (Brown)
3. Middle Claw Setting (Red)
4. High Claw Setting (Orange)

The Connectors J9 and J11 are NOT Used on a standard Toy Chest crane.

CPU Wiring Pinout { continued }

J1 : 25 Pin Connector

1.	Forward / Backward Motor	(Brown / Black)
2.	Left / Right Motor	(Red / Black)
3.	Up / Down Motor	(Orange / Black)
4.	Claw Coil and Analog Meter	(Yellow / Black) x 2
5.	Front Limit Switch	(Green / Black)
6.	Home Limit Switch	(Blue / Black)
7.	N/C	
8.	Left Limit Switch	(Purple / Black)
9.	Up Limit Switch	(Pink / Black)
10.	Down Limit Switch	(Black)
11.	N/C	
12.	N/C	
13.	N/C	
14.	Forward / Backward Motor	(Brown)
15.	Left / Right Motor	(Red)
16.	Up / Down Motor	(Orange)
17.	Claw Coil and Analog Meter	(Yellow) x 2
18.	Ground	(Green)
19.	Ground	(Blue)
20.	Ground	(Purple)
21.	Ground	(Gray)
22.	N/C	
23.	N/C	
24.	N/C	
25.	N/C	

25 Pin D-Sub Connector

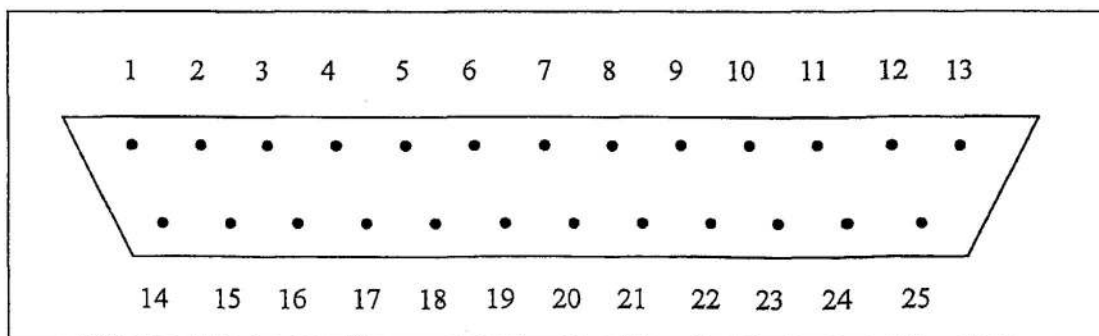

Error Codes :

If an error code is displayed on the display, identify the code and correct the problem and then reset the game to clear the error code.

<u>Error Code</u>	<u>Problem Area</u>	<u>Solution</u>
1	Up and Down Motor	Check Up / Down Limit Switch Check the F1 3A Mini Fuse on CPU
2	Forward and Back Motor	Check Forward / Back Limit Switch
3	Left and Right Motor	Check Left Limit Switch
4	Coin Mech Switch SW1	SW1 on the Coin Mech(s) needs to be in the down position
5	Coin Mech.	Check Coin Selector
8	Main PCB RAM	Replace the RAM
11	Prize Detection Test	The game is in the Prize Detection TEST MODE. Set the DIP Switch SW4 #7 to the OFF position and reset the game.
	Claw don't close	Check 24 Ohm Coil in Claw Check the F2 3A Mini Fuse on CPU

Assembly Part Numbers

The following pages show block diagrams with numbers for each part in the machine. These numbers are to be used when ordering parts for the following Toy Chest Cranes.

Please specify the color of the game when ordering parts.

Toy Chest 24"

Toy Chest Candy Crane 24"

Toy Chest 31"

Toy Chest 41"

Toy Chest 45"

Toy Chest Jumbo 45"

Pirate Chest 31"

Pirate Chest 41"

NOTE:

It is important when ordering parts, to specify which of the games listed above the part is being installed into.

